

Operating Instructions

Compact thermometer

TMR31, TMR35

Metric, compact RTD 4-20 mA thermometer for industrial and hygienic applications



Table of contents

1	About this document	3	9.3	Disposal	16
1.1	Document function	3	10	Accessories	17
1.2	Symbols	3	10.1	Device-specific accessory	17
1.3	Documentation	4	10.2	Online tools	20
2	Basic safety instructions	4	10.3	Communication-specific accessory	21
2.1	Requirements for the personnel	4	10.4	Service-specific accessories	22
2.2	Intended use	5	10.5	System components	22
2.3	Operational safety	5	11	Technical data	23
2.4	Product safety	5	11.1	Input	23
2.5	IT security	5	11.2	Output	23
3	Incoming acceptance and product identification	6	11.3	Power supply	24
3.1	Incoming acceptance	6	11.4	Performance characteristics	25
3.2	Product identification	6	11.5	Environment	27
3.3	Name and address of manufacturer	7	11.6	Process	27
3.4	Storage and transport	7	11.7	Mechanical construction	30
4	Installation	8	11.8	Certificates and approvals	42
4.1	Installation requirements	8			
4.2	Mounting the thermometer	11			
4.3	Post-mounting check	12			
5	Electrical connection	12			
5.1	Connection conditions	12			
5.2	Connecting the measuring instrument ..	12			
5.3	Ensuring the degree of protection	13			
5.4	Post-connection check	13			
6	Commissioning	14			
6.1	Post-installation check	14			
6.2	Switching on the measuring device	14			
6.3	Configuring the measuring device	14			
7	Diagnostics and troubleshooting	14			
7.1	General troubleshooting	14			
8	Maintenance	15			
8.1	Cleaning	15			
8.2	Services	15			
9	Repair	15			
9.1	Spare parts	16			
9.2	Return	16			

1 About this document

1.1 Document function

These Operating Instructions contain all the information required in the various life cycle phases of the device: from product identification, incoming acceptance and storage, to installation, connection, operation and commissioning, through to troubleshooting, maintenance and disposal.

1.2 Symbols

1.2.1 Safety symbols

DANGER

This symbol alerts you to a dangerous situation. Failure to avoid this situation will result in serious or fatal injury.

WARNING

This symbol alerts you to a dangerous situation. Failure to avoid this situation can result in serious or fatal injury.





CAUTION

This symbol alerts you to a dangerous situation. Failure to avoid this situation can result in minor or medium injury.





NOTICE





This symbol contains information on procedures and other facts which do not result in personal injury.

1.2.2 Electrical symbols



Symbol	Meaning	Symbol	Meaning
	Direct current		Alternating current
	Direct current and alternating current		Ground connection A grounded terminal which, as far as the operator is concerned, is grounded via a grounding system.

1.2.3 Symbols for certain types of information

Symbol	Meaning	Symbol	Meaning
	Permitted Procedures, processes or actions that are permitted.		Preferred Procedures, processes or actions that are preferred.
	Forbidden Procedures, processes or actions that are forbidden.		Tip Indicates additional information.

Symbol	Meaning	Symbol	Meaning
	Reference to documentation		Reference to page
	Reference to graphic	1., 2., 3,...	Series of steps
	Result of an individual step		Visual inspection

1.2.4 Symbols in graphics

Symbol	Meaning	Symbol	Meaning
1, 2, 3,...	Item numbers	1., 2., 3,...	Series of steps
A, B, C, ...	Views	A-A, B-B, C-C, ...	Sections
	Hazardous area		Safe area (non-hazardous area)

1.2.5 Tool symbols

Symbol	Meaning
 A0011222	Open-ended wrench

1.3 Documentation

 For an overview of the scope of the associated Technical Documentation, refer to the following:

- *Device Viewer* (www.endress.com/deviceviewer): Enter the serial number from the nameplate
- *Endress+Hauser Operations app*: Enter serial number from nameplate or scan matrix code on nameplate.

2 Basic safety instructions

2.1 Requirements for the personnel

The personnel for installation, commissioning, diagnostics and maintenance must fulfill the following requirements:

- ▶ Trained, qualified specialists must have a relevant qualification for this specific function and task.
- ▶ Are authorized by the plant owner/operator.
- ▶ Are familiar with federal/national regulations.

- ▶ Before starting work, read and understand the instructions in the manual and supplementary documentation as well as the certificates (depending on the application).
- ▶ Follow instructions and comply with basic conditions.

The operating personnel must fulfill the following requirements:

- ▶ Are instructed and authorized according to the requirements of the task by the facility's owner-operator.
- ▶ Follow the instructions in this manual.

2.2 Intended use

- The device is a compact thermometer for industrial temperature measurement.
- The manufacturer is not liable for damage caused by improper or non-designated use.

2.3 Operational safety

Damage to the device!

- ▶ Operate the device in proper technical condition and fail-safe condition only.
- ▶ The operator is responsible for the interference-free operation of the device.

Modifications to the device

Unauthorized modifications to the device are not permitted and can lead to unforeseeable dangers!

- ▶ If modifications are nevertheless required, consult with the manufacturer.

Repair

To ensure continued operational safety and reliability:

- ▶ Carry out repairs on the device only if they are expressly permitted.
- ▶ Observe federal/national regulations pertaining to the repair of an electrical device.
- ▶ Use only original spare parts and accessories.

2.4 Product safety

This state-of-the-art device is designed and tested in accordance with good engineering practice to meet operational safety standards. It left the factory in a condition in which it is safe to operate.

It meets general safety standards and legal requirements. It also complies with the EU directives listed in the device-specific EU declaration of conformity. The manufacturer confirms this by affixing the CE mark.

2.5 IT security

The manufacturer warranty is valid only if the product is installed and used as described in the Operating Instructions. The product is equipped with security mechanisms to protect it against any inadvertent changes to the settings.

IT security measures, which provide additional protection for the product and associated data transfer, must be implemented by the operators themselves in line with their security standards.

3 Incoming acceptance and product identification

3.1 Incoming acceptance

On receipt of the delivery:

1. Check the packaging for damage.
 - ↳ Report all damage immediately to the manufacturer.
Do not install damaged components.
2. Check the scope of delivery using the delivery note.
3. Compare the data on the nameplate with the order specifications on the delivery note.
4. Check the technical documentation and all other necessary documents, e.g. certificates, to ensure they are complete.



If one of the conditions is not satisfied, contact the manufacturer.

3.2 Product identification

The following options are available for the identification of the device:

- Nameplate specifications
- Enter the serial number from the nameplate in the *Device Viewer* www.endress.com/deviceviewer: all data relating to the device and an overview of the Technical Documentation supplied with the device are displayed.

3.2.1 Nameplate

The correct device?

1. Check the data on the nameplate of the device.
2. Compare against the requirements of the measuring point.

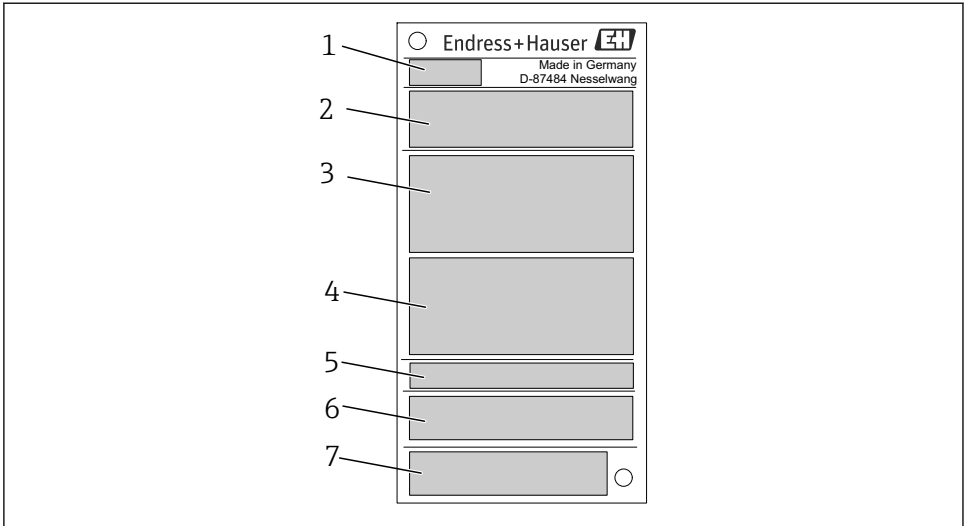

A0038995

1 Sample graphic

- 1 Product root, device designation
- 2 Order code, serial number
- 3 Tag name
- 4 Technical values: supply voltage, current consumption, ambient temperature
- 5 Degree of protection
- 6 Pin assignment
- 7 Approvals with symbols: CE mark, EAC

3.2.2 Scope of delivery

The scope of delivery comprises:

- Compact thermometer
- Printed copy of the Brief Operating Instructions
- Accessories ordered

3.3 Name and address of manufacturer

Name of manufacturer:	Endress+Hauser Wetzer GmbH + Co. KG
Address of manufacturer:	Obere Wank 1, D-87484 Nesselwang or www.endress.com

3.4 Storage and transport

Storage temperature: -40 to +85 °C (-40 to +185 °F).

Avoid the following environmental influences during storage:



- Direct sunlight
- Proximity to hot objects
- Mechanical vibration
- Aggressive media

Maximum relative humidity: < 95%

 Pack the device for storage and transportation in such a way that it is reliably protected against impact and external influences. The original packaging provides the best protection.

4 Installation

4.1 Installation requirements

 For information on the conditions that must be present at the mounting location to ensure correct use (e.g. ambient temperature, degree of protection, climate class etc.), and information on the device dimensions, see the 'Technical data' →  23

4.1.1 Orientation

No restrictions. However, self-draining in the process must be guaranteed. If there is an opening to detect leaks at the process connection, this opening must be at the lowest possible point.

4.1.2 Installation instructions

The immersion length of the compact thermometer can considerably influence the measurement accuracy. If the immersion length is too short, measurement errors can occur as a result of heat conduction via the process connection and the vessel wall. Therefore, if installing in a pipe, the immersion length should ideally correspond to half of the pipe diameter.

Installation possibilities: pipes, tanks or other plant components.

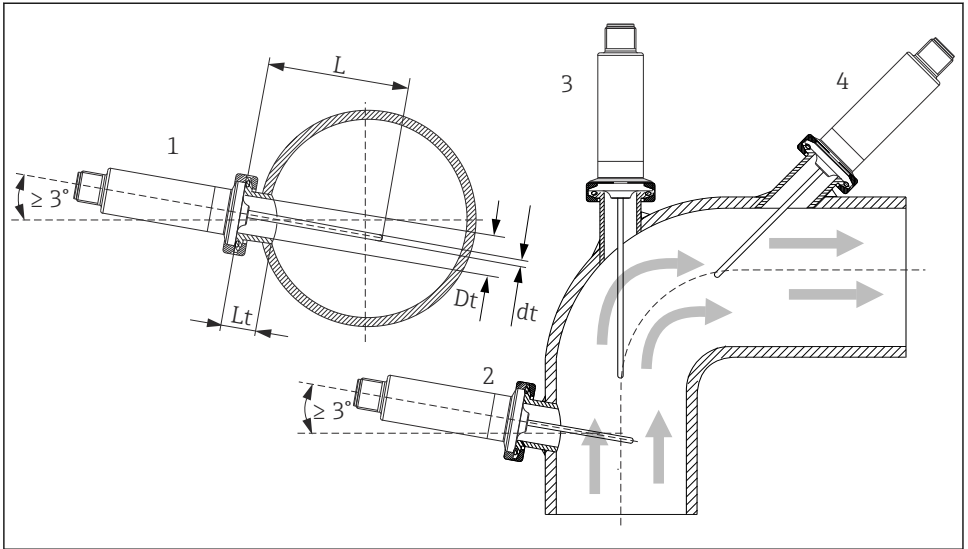

A0012591

2 Installation examples

- 1, 2 Perpendicular to the flow direction, installed at a min. angle of 3° to ensure self-draining
- 3 On elbows
- 4 Inclined installation in pipes with a small nominal diameter
- L Insertion length



The requirements of the EHEDG and the 3-A Sanitary Standard must be adhered to.

Installation instruction EHEDG/cleanability: $L_t \leq (D_t - d_t)$

Installation instruction 3-A/cleanability: $L_t \leq 2(D_t - d_t)$



In the case of pipes with a small nominal diameter, it is advisable for the tip of the thermometer to project well into the process so that it extends past the pipe axis. Installation at an angle (4) could be another solution. When determining the immersion or insertion length, all the parameters of the thermometer and of the medium to be measured must be taken into account (e.g. flow velocity, process pressure).

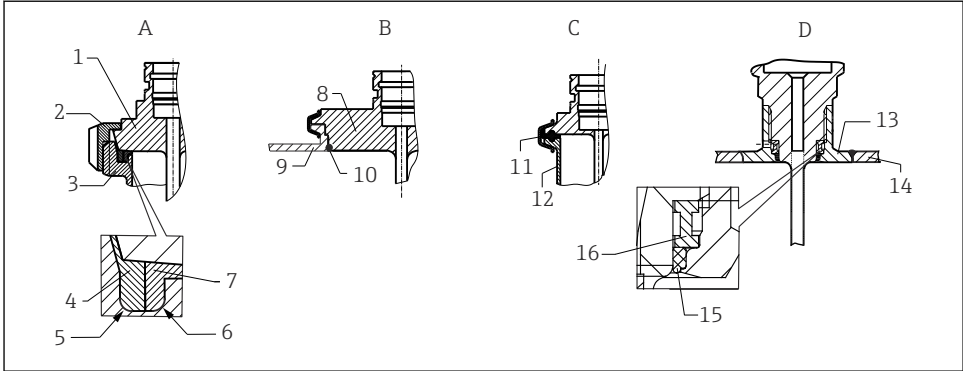

A0040345

3 Detailed installation instructions for hygiene-compliant installation

A Milk pipe connection according to DIN 11851, only in conjunction with EHEDG-certified, self-centering sealing ring

1 Sensor with milk pipe connection

2 Groove slip-on nut

3 Counterpart connection

4 Centering ring

5 RO.4

6 RO.4

7 Sealing ring

B Varivent® process connection for VARINLINE® housing

8 Sensor with Varivent connection

9 Counterpart connection

10 O-ring

C Clamp according to ISO 2852

11 Molded seal

12 Counterpart connection

D Process connection Liquiphant-M G1", horizontal installation

13 Weld-in adapter

14 Vessel wall

15 O-ring

16 Thrust collar

i The counterpieces for the process connections and the seals or sealing rings are not supplied with the thermometer. Liquiphant M weld-in adapters with associated seal kits are available as accessories (see 'Accessories').

NOTICE

The following actions must be taken if a sealing ring (O-ring) or seal fails:

- ▶ The thermometer must be removed.
- ▶ The thread and the O-ring joint/sealing surface must be cleaned.
- ▶ The sealing ring or seal must be replaced.
- ▶ CIP must be performed after installation.

In the case of weld-in connections, exercise the necessary degree of care when performing the welding work on the process side:

1. Use suitable welding material.
2. Flush-weld or weld with welding radius ≥ 3.2 mm (0.13 in).
3. Avoid crevices, folds or gaps.
4. Ensure the surface is honed and mechanically polished, $R_a \leq 0.76$ μm (30 μin).

Pay attention to the following when installing the thermometer to ensure that the cleanability is not affected:

1. The installed sensor is suitable for CIP (cleaning in place). Cleaning is carried out in combination with piping or tank. In the case of internal tank fixtures using process connection nozzles, it is important to ensure that the cleaning assembly sprays this area directly so that it is cleaned properly.
2. The Varivent® connections enable flush-mounted installation.

4.2 Mounting the thermometer

Proceed as follows to mount the device:

1. The permitted loading capacity of the process connections can be found in the relevant standards.
2. The process connection and compression fitting must comply with the maximum specified process pressure.
3. Make sure that the device is installed and secured before applying the process pressure.
4. Adjust the loading capacity of the thermowell to the process conditions.
5. It may be necessary to calculate the static and dynamic loading capacity.



It is possible to verify the mechanical loading capacity as a function of the installation and process conditions using the online TW Sizing Module for thermowells in the Endress+Hauser Applicator software <https://portal.endress.com/webapp/applicator>.

4.2.1 Cylindrical threads

NOTICE

Seals must be used for cylindrical threads.

In the case of combined thermometer and thermowell assemblies, these seals are already installed (depending on the version ordered).

- ▶ The system operator is required to verify the suitability of this seal with regard to the operating conditions.

Threaded version	Tightening torque [Nm]
Process connection, metal sealing system	10
Compression fitting, cylindrical, Elastosil seal	5

1. Replace with a suitable seal if necessary.
2. Replace the seals following disassembly.
3. As all threads must be firmly tightened, using the appropriate torques.

4.2.2 Tapered threads

- ▶ The operator must verify if additional sealing by means of PTFE tape, hemp or an additional welded seam, for example, is necessary in the case of NPT threads or other tapered threads.

4.3 Post-mounting check

<input type="checkbox"/>	Is the device undamaged (visual inspection)?
<input type="checkbox"/>	Is the device correctly secured?
<input type="checkbox"/>	Does the device correspond to the specifications at the measuring point, e.g. ambient temperature, measuring range etc.? →  23

5 Electrical connection

5.1 Connection conditions

-  If the 3-A Standard is required, electrical connecting cables must be smooth, corrosion-resistant and easy to clean.

5.2 Connecting the measuring instrument

NOTICE

Damage to the device!

- ▶ Do not overtighten the M12 plug, as this could damage the device. Maximum torque: 0.4 Nm (M12 knurl)

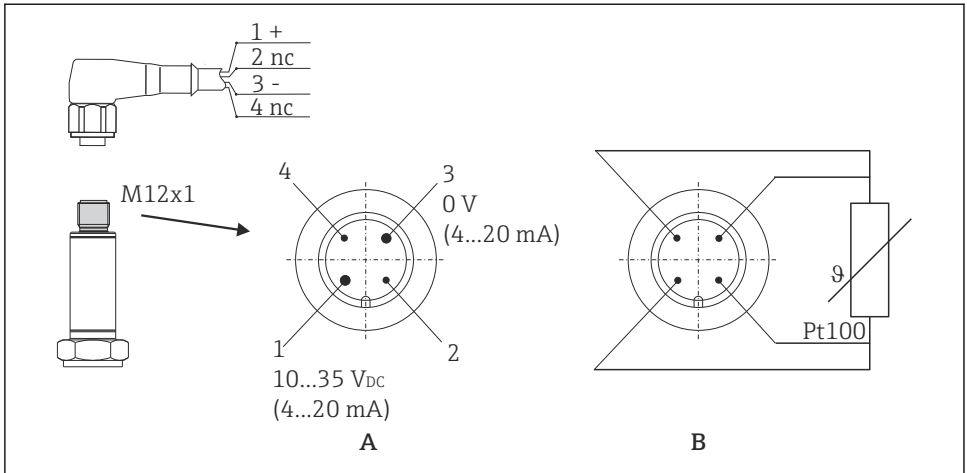

A0020176

4 Pin assignment, device plug

A Version with transmitter, M12 plug, 4-pin

B Version without transmitter, Pt100, 4-wire connection

1: Pin 1	10 to 35 V _{DC} power supply 4 to 20 current output Cable connection, wire color brown = BN
2: Pin 2	Connection of PC configuration cable - shortened pin Cable connection, wire color white = WH
3: Pin 3	0 V _{DC} power supply 4 to 20 current output Cable connection, wire color blue = BU
4: Pin 4	Connection of PC configuration cable - shortened pin Cable connection, wire color black = BK

5.3 Ensuring the degree of protection

The indicated degree of protection is ensured if the M12x1 cable connector meets the required degree of tightness. For compliance with IP69 protection, suitable device connecting cables with straight or elbowed connectors are available .



5.4 Post-connection check

<input type="checkbox"/>	Are the device and cable undamaged (visual check)?
<input type="checkbox"/>	Do the mounted cables have suitable strain relief?
<input type="checkbox"/>	Does the supply voltage match the information on the nameplate?

6 Commissioning

6.1 Post-installation check

Perform the following checks prior to commissioning the measuring point:

1. Perform the post-mounting check using the checklist →  12.
2. Perform the post-connection check using the checklist →  13.

6.2 Switching on the measuring device

After applying the supply voltage, the device is in the measuring mode.

6.3 Configuring the measuring device

The compact thermometer is configured via the TXU10 configuration set, for PC-programmable thermometers with the ReadWin 2000 setup software and an interface for PC with USB port.



Configurable parameters	
Standard settings	<ul style="list-style-type: none"> ▪ Measuring unit (°C/°F) ▪ Measuring range limits: <ul style="list-style-type: none"> ▪ -50 to +150 °C (-58 to +302 °F) without extension neck ▪ -50 to +200 °C (-58 to +392 °F) with extension neck
Advanced settings	<ul style="list-style-type: none"> ▪ Failure mode ▪ Output (analog standard/inverse) ▪ Filter: 0 to 8 s ▪ Offset: -9.9 to +9.9 K ▪ Device TAG
Service functions	Simulation (on/off)

7 Diagnostics and troubleshooting

7.1 General troubleshooting



Due to its design, the device cannot be repaired. However, it is possible to send the device in for inspection. →  16

Problem	Possible cause	Remedial action
Device does not respond.	Supply voltage does not match the voltage specified on the nameplate.	▶ Connect the correct voltage.
Device measures incorrectly.	The device has been incorrectly connected.	▶ Check the pin assignment →  12.
	Incorrect device orientation.	▶ Install the device correctly. →  8

Problem	Possible cause	Remedial action
	Heat dissipation over the measuring point.	► Observe the installed length of the sensor.
No communication	Communication cable is not connected.	► Check wiring and cables.

Behavior of the device in the event of a fault

The behavior of the output in the event of a failure is regulated in accordance with NAMUR NE43. The current output adopts the configured failure current. →  23

8 Maintenance

No special maintenance work is required.

8.1 Cleaning

The device must be cleaned whenever necessary. Cleaning can also be done when the device is installed (e.g. CIP Cleaning in Place / SIP Sterilization in Place). When cleaning the device, care must be taken to ensure that it is not damaged.

NOTICE

Avoid damage to the device and the system

- Pay attention to the specific IP code when cleaning.

8.2 Services

Service	Description
Calibration	RTD inserts may drift depending on the application. Regular recalibration to verify accuracy is recommended. The calibration can be performed by the manufacturer or by qualified technical staff using calibration devices onsite.

9 Repair

Due to its design, the device cannot be repaired.

9.1 Spare parts

Spare parts currently available for your product can be found online at:

http://www.products.endress.com/spareparts_consumables. Always quote the serial number of the device when ordering spare parts!

Type	Order code	TMR31	TMR35
Adapter upgrade TXU10	51007657	✓	
Collar welding boss d6 PEEK+screw	51004751	✓	
Collar welding boss d6 PEEK w/o screw	51004752	✓	
Screw G½"+sealing taper	51007599	✓	
Cable M12x1, length 5 m	51005148	✓	
4-pin plug M12x1, cable assembly	51006327	✓	
Cable set 4p D18 IP69K	71217708	✓	
Weld-in adapter G3/4, d=50, 316L, 3.1	52018765		✓
Weld-in adapter G3/4, 316L, 3.1	52011897		✓
Welding boss for G1/2" sealing system	71424800		✓
O-ring 14.9x2.7 VMQ, FDA, 5 pcs.	52021717		✓
Weld-in adapter G3/4, d=55, 316L	52001052		✓
O-ring 21.89x2.62 VMQ, FDA, 5 pcs.	52014473		✓
Weld-in adapter G1, d=60, 316L	52001051		✓
Weld-in adapter G1, d=60, 316L, 3.1	52011896		✓
O-ring 28.17x3.53 VMQ, FDA, 5 pcs.	52014472		✓
Thermowell TMR35, L = 83 mm, G½", 316L	51327121		✓
Compression fitting, movable	TA50-	✓	

9.2 Return

The requirements for safe device return can vary depending on the device type and national legislation.

1. Refer to the web page for information: <https://www.endress.com>
2. If returning the device, pack the device in such a way that it is reliably protected against impact and external influences. The original packaging provides the best protection.

9.3 Disposal

The device contains electronic components and must therefore be disposed of as electronic waste. Please pay particular attention to the local regulations governing waste disposal in your country. Ensure proper separation and reuse of the device components where possible.

10 Accessories

The accessories currently available for the product can be selected at www.endress.com:

1. Select the product using the filters and search field.
2. Open the product page.
3. Select **Spare parts & Accessories**.

10.1 Device-specific accessory

All dimensions in mm (in).

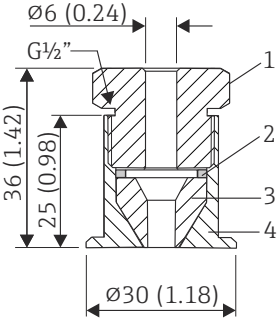
Accessory	Description
<p>Welding boss with sealing taper</p>  <p style="text-align: right; font-size: small;">A0048610</p> <p>1 Pressure screw, 303/304, width across flats 24 mm 2 Washer, 303/304 3 Sealing taper, PEEK 4 Collar welding boss, 316L</p>	<ul style="list-style-type: none"> ■ Collar welding boss movable with sealing taper, washer and pressure screw G1/2" ■ Material of parts in contact with the process 316L, PEEK ■ Max. process pressure 10 bar (145 psi)

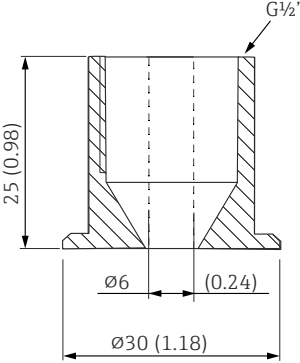
Accessory	Description
<p data-bbox="174 180 329 201">Collar welding boss</p>  <p data-bbox="400 608 452 624">A0020710</p>	<p data-bbox="465 180 863 201">Material of parts in contact with the process 316L</p>

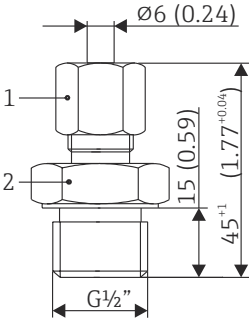
Accessory	Description
<p data-bbox="174 715 329 735">Compression fitting</p>  <p data-bbox="70 1126 152 1174"> 1 AF14 2 AF27 </p> <p data-bbox="400 1098 452 1114">A0048609</p>	<ul data-bbox="465 715 972 858" style="list-style-type: none"> ▪ Adjustable clamping ring, for process connections G$\frac{1}{2}$", G$\frac{3}{4}$", G1", NPT $\frac{1}{2}$", etc. ▪ Material of compression fitting and parts in contact with the process, 316L ▪ Order number TA50-HB (other versions can be configured in the TA50 structure)

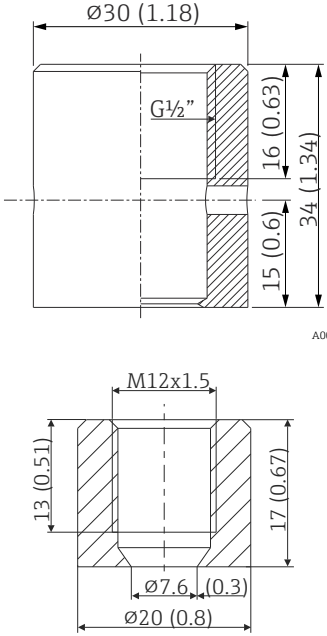
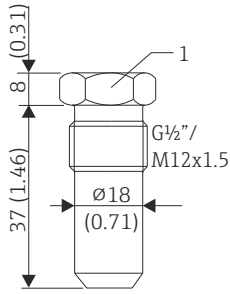
Accessory	Description
<p>Welding boss with sealing taper (metal-metal)</p>  <p style="text-align: right;">A0006621</p> <p style="text-align: right;">A0018236</p>	<ul style="list-style-type: none"> ■ Welding boss for G½" or M12x1.5 thread ■ Metal-sealing; conical ■ Material of parts in contact with the process 316L/1.4435 ■ Max. process pressure 16 bar (232 PSI)
<p>Dummy plug</p>  <p style="text-align: right;">A0045726</p> <p>1 AF22</p>	<ul style="list-style-type: none"> ■ Dummy plug for G½" or M12x1.5 conical metal-sealing welding boss ■ Material: SS 316L/1.4435

10.1.1 Weld-in adapter

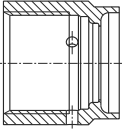
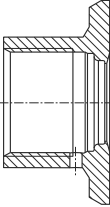
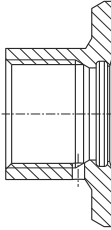
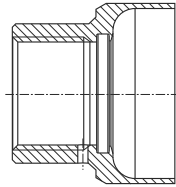
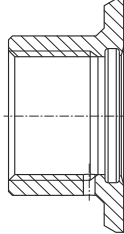
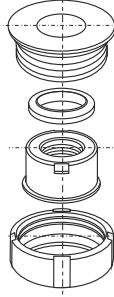

For more information about order codes and hygienic compliance of the adapters and spare parts, see Technical Information (TI00426F).

Weld-in adapter	 A0008246	 A0008251	 A0008256	 A0011924	 A0008248	 A0008253
	G 3/4", d=29 for pipe-mounting	G 3/4", d=50 for vessel-mounting	G 3/4", d=55 with flange	G 1", d=53 without flange	G 1", d=60 with flange	G 1" adjustable
Material	316L (1.4435)	316L (1.4435)	316L (1.4435)	316L (1.4435)	316L (1.4435)	316L (1.4435)
Roughness μm (μin) process side	≤ 1.5 (59.1)	≤ 0.8 (31.5)	≤ 0.8 (31.5)	≤ 0.8 (31.5)	≤ 0.8 (31.5)	≤ 0.8 (31.5)

- i** Maximum process pressure for the weld-in adapters:
- 25 bar (362 PSI) at maximum 150 °C (302 °F)
 - 40 bar (580 PSI) at maximum 100 °C (212 °F)

10.2 Online tools

Product information over the entire life cycle of the device: www.endress.com/onlinetools

10.3 Communication-specific accessory

10.3.1 Coupling

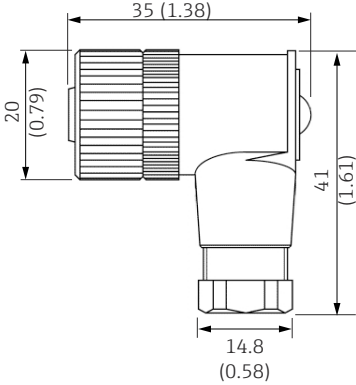
Accessory	Description
<ul style="list-style-type: none"> ▪ M12x1 coupling; elbowed, for termination of connecting cable by user ▪ Connection to M12x1 housing connector ▪ Body materials PBT/PA ▪ Coupling nut GD-Zn, nickel-plated ▪ IP67 degree of protection (fully locked) ▪ Voltage: max. 250 V ▪ Current carrying capacity: max. 4 A ▪ Temperature: -40 to 85 °C 	 <p style="text-align: right;">A0020722</p>

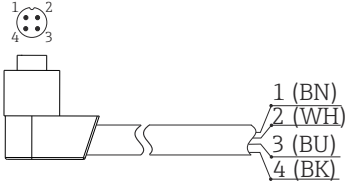
Accessory	Description
<ul style="list-style-type: none"> ▪ PVC cable, 4 x 0.34 mm² (22 AWG) with M12x1 coupling, elbow plug, screw plug, length 5 m (16.4 ft) ▪ IP69K protection (optional) ▪ Voltage: max. 250 V ▪ Current carrying capacity: max. 4 A ▪ Temperature: -25 to 70 °C <p>Wire colors:</p> <ul style="list-style-type: none"> ▪ 1 = BN brown ▪ 2 = WH white ▪ 3 = BU blue ▪ 4 = BK black 	 <p style="text-align: right;">A0020723</p>

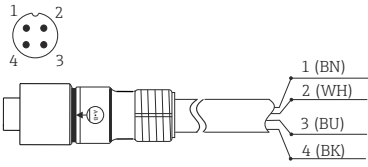
Accessory	Description
<ul style="list-style-type: none"> ▪ PVC cable, 4 x 0.34 mm² (22 AWG) with M12x1 coupling nut made of epoxy coated zinc, straight socket contact, screw plug, 5 m (16.4 ft) ▪ IP69K protection (optional) ▪ Voltage: max. 250 V ▪ Current carrying capacity: max. 4 A ▪ Temperature: -20 to 105 °C <p>Wire colors:</p> <ul style="list-style-type: none"> ▪ 1 = BN brown ▪ 2 = WH white ▪ 3 = BU blue ▪ 4 = BK black 	 <p style="text-align: right;">A0020725</p>

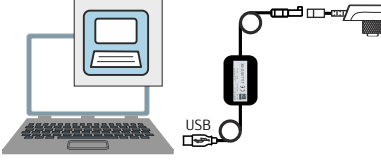
Accessory	Description
Configuration kit for PC-programmable transmitters - setup program and interface cable (4-pin connector) for PC with USB port + adapter for compact thermometer with M12x1 thread Order code: TXU10	 <p style="text-align: right; font-size: small;">A0028635</p>

10.4 Service-specific accessories

Applicator

Software for selecting and sizing Endress+Hauser measuring devices:

- Calculation of all the necessary data for identifying the optimum measuring device: e.g. pressure loss, accuracy or process connections.
- Graphic illustration of the calculation results

Administration, documentation and access to all project-related data and parameters over the entire life cycle of a project.

Applicator is available:

<https://portal.endress.com/webapp/applicator>

Configurator

Product Configurator - the tool for individual product configuration

- Up-to-the-minute configuration data
- Depending on the device: direct input of information specific to the measuring point, such as the measuring range or operating language
- Automatic verification of exclusion criteria
- Automatic creation of the order code and its breakdown in PDF or Excel output format
- Ability to order directly in the Endress+Hauser Online Shop

The Configurator is available at www.endress.com on the relevant product page:

1. Select the product using the filters and search field.
2. Open the product page.
3. Select **Configuration**.

10.5 System components

Process indicators from the RIA product family

Easily readable process indicators with various functions: loop-powered indicators for displaying 4 to 20 mA values, display of up to four HART variables, process indicators with control units, limit value monitoring, sensor power supply, and galvanic isolation.

Universal application thanks to international hazardous area approvals, suitable for panel mounting or field installation..

For more information, please refer to: www.endress.com

RN series active barrier

Single- or two-channel active barrier for safe separation of 0/4 to 20 mA standard signal circuits with bidirectional HART transmission. In the signal duplicator option, the input signal is transmitted to two galvanically isolated outputs. The device has one active and one passive current input; the outputs can be operated actively or passively.

For more information, please refer to: www.endress.com

11 Technical data

11.1 Input

11.1.1 Measuring range

Pt100 (TF) according to IEC 60751

Without extension neck	-50 to +150 °C (-58 to +302 °F)
With extension neck	-50 to +200 °C (-58 to +392 °F)

Min. span = 10 K (18 °F)

11.2 Output

11.2.1 Output signal

Sensor output	Pt100, 4-wire connection, class A
Analog output	4 to 20 mA; variable measuring range

11.2.2 Signal on alarm

The signal on alarm is generated if the measuring information is missing or not valid.

In the 4 to 20 mA mode, the device transmits the failure information according to NAMUR NE43:

Underranging	Linear drop from 4.0 to 3.8 mA
Overranging	Linear increase from 20.0 to 20.5 mA
Failure e.g. sensor defective	≤ 3.6 mA (low) or ≥ 21 mA (high) can be selected The high alarm setting can be set between 21.5 mA and 23 mA, thus providing the flexibility needed to meet the requirements of various control systems.

11.2.3 Load

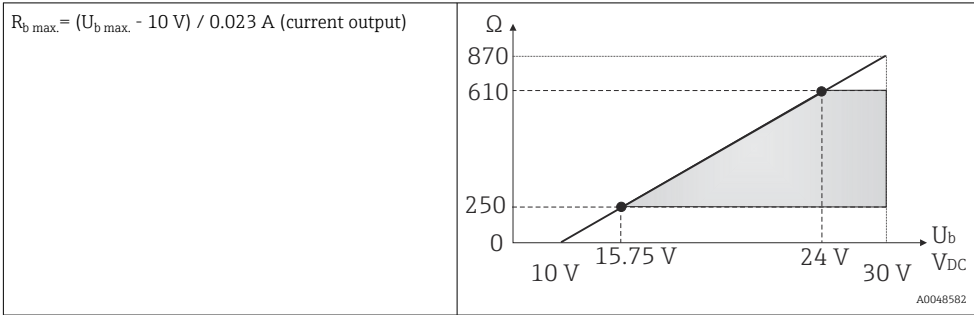

11.2.4 Linearization/transmission behavior

Temperature - linear

11.3 Power supply

11.3.1 Supply voltage

U_b	10 to 35 V _{DC}
-------	--------------------------

11.3.2 Power supply failure

- To meet electrical safety according to CAN/CSA-C22.2 No. 61010-1 or UL 61010-1, the device may only be powered by a power supply unit with a limited energy electric circuit in accordance with UL/EN/IEC 61010-1 chapter 9.4 or Class 2 according to UL 1310, "SELV or Class 2 circuit".
- Behavior in the event of overvoltage (> 30 V)
The device works continuously up to 35 V_{DC} without any damage. If the supply voltage is exceeded, the specified characteristics are no longer guaranteed.
- Behavior in the event of undervoltage
If the supply voltage falls below the minimum value ~ 7 V, the device switches off in a defined manner (status as if not supplied with power).

11.3.3 Input current required

≤ 3.5 mA for 4 to 20 mA

11.3.4 Maximum current consumption

≤ 23 mA for 4 to 20 mA

11.3.5 Switch-on delay

2 s

11.3.6 Overvoltage protection

To protect against overvoltage in the power supply and signal/communication cables for the thermometer electronics, the manufacturer offers the HAW562 surge arrester for DIN rail mounting.



See the technical documentation of the specific device.

11.4 Performance characteristics

11.4.1 Reference operating conditions

Adjustment temperature (ice bath)	0 °C (32 °F) for sensor
Ambient temperature range	25 °C ± 3 °C (77 °F ± 5 °F) for electronics
Supply voltage	24 V _{DC} ± 10 %
Relative humidity	< 95 %

11.4.2 Maximum measured error

According to DIN EN 60770 and the reference conditions specified above. The measured error data correspond to $\pm 2 \sigma$ (Gaussian distribution). The data include non-linearities and repeatability.



$|T|$ = Numerical value of the temperature in °C without regard to algebraic sign.

Thermometer without electronics

Standard	Designation	Measuring range	Measured error ME (±)	
			Maximum ¹⁾	Based on measured value ²⁾
IEC 60751	Pt100 Cl. A	-50 to +200 °C (-58 to +392 °F)	0.55 K (0.99 °F)	ME = ± (0.15 K (0.27 °F) + 0.002 * T)

- 1) Maximum measured error for the specified measuring range.
- 2) Deviations from maximum measured error possible due to rounding.

Thermometer with electronics

Standard	Designation	Measuring range	Measured error (±) ¹⁾
IEC 60751	Pt100 Cl. A	-50 to +200 °C (-58 to +392 °F)	0.1 K (0.18 °F) or 0.08 %

- 1) Percentage refers to the set span. The larger value is valid.

Total measured error of thermometer (sensor + electronics)

Standard	Designation	Measuring range	Measured error ME (\pm) ¹⁾
IEC 60751	Pt100 Cl. A	<ul style="list-style-type: none"> ▪ -50 to +150 °C (-58 to +302 °F) without extension neck ▪ -50 to +200 °C (-58 to +392 °F) with extension neck 	$ME = \pm (0.25 \text{ K (0.48 °F)} + 0.002 * T)$

1) Deviations from maximum measured error possible due to rounding.

11.4.3 Long-term drift

Electronics:

$\leq 0.1 \text{ K (0.18 °F)}/\text{year}$ or $0.05 \text{ %}/\text{year}$

Data under reference operating conditions. % refers to the set span. The larger value is valid.

11.4.4 Operating influences

The measured error data correspond to $\pm 2 \sigma$ (Gaussian distribution).

Ambient temperature	$T = \pm(15 \text{ ppm/K} * (\text{full scale value} + 200) + 50 \text{ ppm/K} * \text{set measuring range}) * DT$ DT = deviation of ambient temperature from the reference operating conditions
Supply voltage	$\leq \pm 0.01\%/V$ deviation from $24 \text{ V}^{1)}$
Load	$\pm 0.02\%/100 \Omega^{1)}$

1) Specifications in percent refer to the full scale value of the measuring range

11.4.5 Sensor response time

Tests in water at 0.4 m/s (1.3 ft/s) according to IEC 60751; temperature changes in increments of 10 K . Response times measured for the version without electronics.

t_{50}	t_{90}
$< 1 \text{ s}$	$< 2 \text{ s}$

11.4.6 Electronics response time

Max. 1 s

 When recording step responses, it is important to bear in mind that the response times of the sensor might be added to the specified times.

11.4.7 Sensor current

$\leq 0.6 \text{ mA}$

11.5 Environment

11.5.1 Ambient temperature range

T_a	-40 to +85 °C (-40 to +185 °F)
-------	--------------------------------

11.5.2 Storage temperature



Pack the device so that it is reliably protected against impact when it is stored (and transported). The original packaging offers the best protection.

T_s	-40 to +85 °C (-40 to +185 °F)
-------	--------------------------------

11.5.3 Operating altitude

Up to 2 000 m (6 600 ft) above sea level

11.5.4 Climate class

In accordance with IEC/EN 60654-1, class C

11.5.5 Degree of protection

As per IEC/EN 60529: IP67 with coupling and connecting cable (not evaluated by UL). Depends on the degree of protection of the connection cable. → 21

11.5.6 Shock and vibration resistance

4g in the range from 2 to 150 Hz as per DIN EN 60068-2-6

11.5.7 Electromagnetic compatibility (EMC)

Electromagnetic compatibility in accordance with all the relevant requirements of the IEC/EN 61326 series and NAMUR Recommendation EMC (NE21). For details refer to the EU Declaration of Conformity.

Maximum measurement error < 1% of the measuring range.

Interference immunity as per IEC/EN 61326 series, industrial requirements

Interference emission as per IEC/EN 61326 series, Class B equipment

11.5.8 Electrical safety

- Protection class III
- Overvoltage category II
- Pollution level 2

11.6 Process

11.6.1 Process temperature range

The thermometer electronics must be protected against temperatures over 85 °C (185 °F) by an extension neck of the appropriate length.

Device version without electronics

Independent of the extension neck	-50 to +200 °C (-58 to +392 °F)
--	---------------------------------

Device version with electronics

Without extension neck	-50 to +150 °C (-58 to +302 °F)
With extension neck	-50 to +200 °C (-58 to +392 °F)

The following restrictions apply for the thermometer for general applications with a process connection, depending on the process connection and ambient temperature:

- If mounting with process connections with an adjustable insertion length, e.g. compression fitting with sealing taper, a corresponding extension neck length must be taken into consideration when installing. →  17
- Ambient temperatures must be taken into consideration

Maximum ambient temperature	Maximum process temperature	
	Without extension neck	With extension neck length 35 mm (1.38 in)
≤ 25 °C (77 °F)	150 °C (302 °F)	200 °C (392 °F)
≤ 40 °C (104 °F)	135 °C (275 °F)	180 °C (356 °F)
≤ 60 °C (140 °F)	120 °C (248 °F)	160 °C (320 °F)
≤ 85 °C (185 °F)	100 °C (212 °F)	133 °C (271 °F)

11.6.2 Process pressure range

The maximum possible process pressure depends on various influencing factors, such as the design, process connection and process temperature. Maximum possible process pressures for the individual process connections. →  34

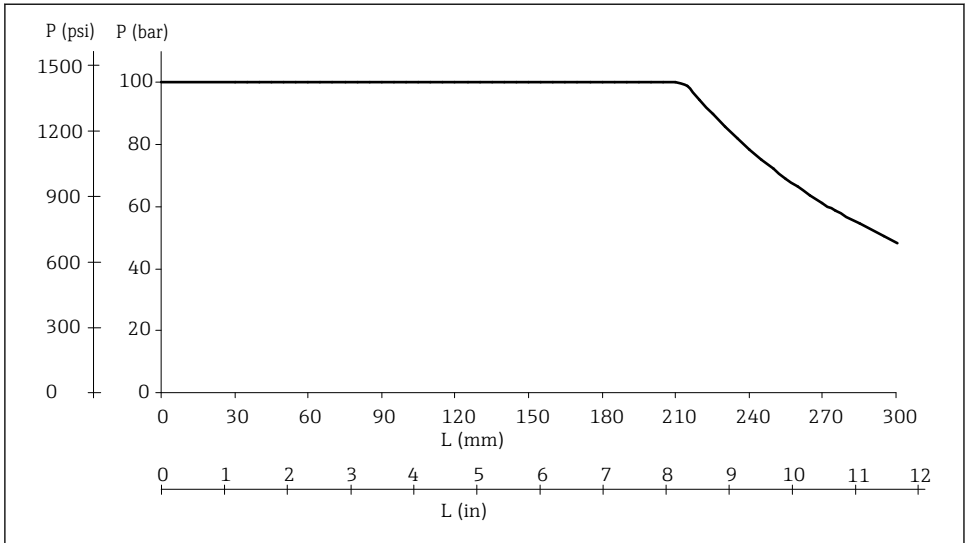

A0008063

5 *Maximum permitted process pressure*

L Insertion length

p Process pressure

The diagram takes into consideration not only the overpressure but also the compressive load caused by flow, wherein a safety factor of 1.9 has been applied for operation with flow. The maximum permitted static operating pressure is lower for longer insertion lengths due to the increased bending load caused by the flow. This calculation is based on the maximum permitted flow velocity for the respective insertion length (see diagram below).

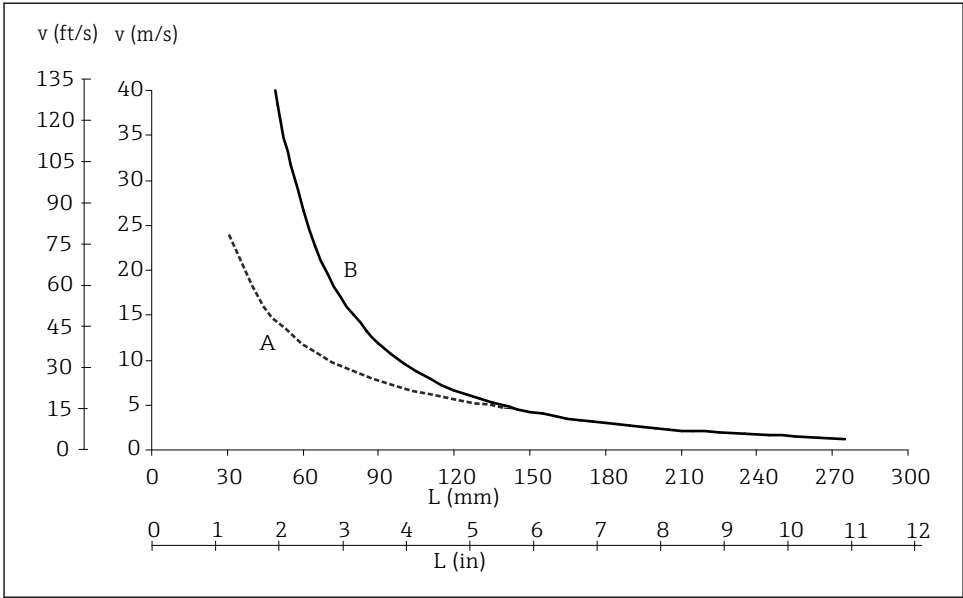

A0008065

6 Permitted flow velocity depending on the insertion length

L Insertion length during flow

v Flow velocity

A Medium water at $T = 50\text{ °C}$ (122 °F)

B Medium superheated steam at $T = 200\text{ °C}$ (392 °F)

The permitted flow velocity is the minimum from the resonance velocity (resonance distance 80%) and the load or buckling caused by flow, which would result in the failure of the thermometer tube or the undershooting of the safety factor (1.9). The calculation was performed for the specified limit operating conditions of $T = 200\text{ °C}$ (392 °F) and process pressure $p \leq 100\text{ bar}$ (1450 psi).

i It is possible to verify the mechanical loading capacity as a function of the installation and process conditions using the online TW Sizing Module for thermowells in the Endress+Hauser Applicator software. → 17

11.6.3 State of aggregation of the medium

Gaseous or liquid (also with high viscosity, e.g. yogurt).

11.7 Mechanical construction

11.7.1 Design, dimensions

Thermometers for general applications

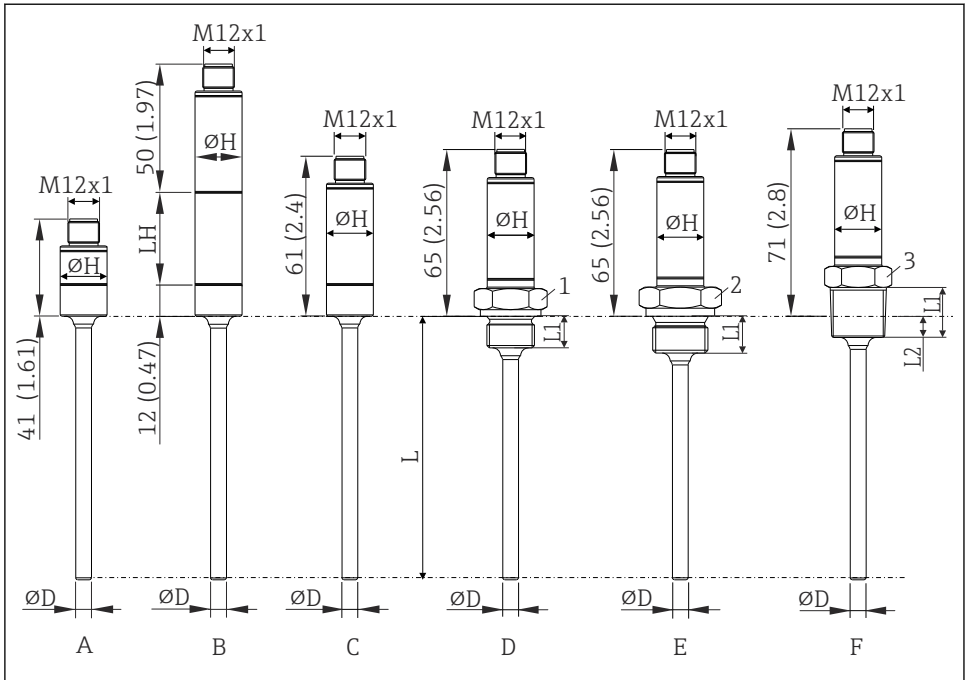

A0020192

7 Dimensions in mm (inch)

L Insertion length *L*, variable 40 to 600 mm (1.6 to 23.6 in)

$\varnothing D$ Diameter *D* 6 mm (0.25 in)

$\varnothing H$ Sleeve diameter 18 mm (0.71 in)

Item	Version	Thread length L_1	Thread length L_2	P_{max}
A	Shortened sleeve (without built-in transmitter, without extension neck, without process connection). For suitable welding bosses and compression fittings, see the Accessories section.	-	-	-
B	With extension neck; L_H = Extension neck length 35 mm or 50 mm (1.38 in or 1.97 in), without process connection. For suitable welding bosses and compression fittings, see the Accessories section.	-	-	-
C	Without extension neck, without process connection. For suitable welding bosses and compression fittings, see the Accessories section.	-	-	-

Item	Version	Thread length L ₁	Thread length L ₂	P _{max.}
D	Without extension neck, metric threaded process connection: <ul style="list-style-type: none"> ■ M14x1.5 (1 = AF19) ■ M18x1.5 (1 = AF24) 	12 mm (0.47 in)	-	100 bar (1450 psi)
E	Without extension neck, threaded process connection, cylindrical as per ISO 228: <ul style="list-style-type: none"> ■ G$\frac{1}{4}$" (2 = AF19) ■ G$\frac{1}{2}$" (2 = AF27) 	12 mm (0.47 in) 14 mm (0.55 in)	- -	
F	Without extension neck, threaded process connection in inches, conical: <ul style="list-style-type: none"> ■ ANSI NPT $\frac{1}{4}$" (3 = AF19) ■ ANSI NPT $\frac{1}{2}$" (3 = AF27) ■ BSPT R $\frac{1}{2}$" (3 = AF/22) 	14.3 mm (0.56 in) 19 mm (0.75 in) 19 mm (0.75 in)	5.8 mm (0.23 in) 8.1 mm (0.32 in) 8.1 mm (0.32 in)	

11.7.2 Design, dimensions

Thermometers for hygienic applications

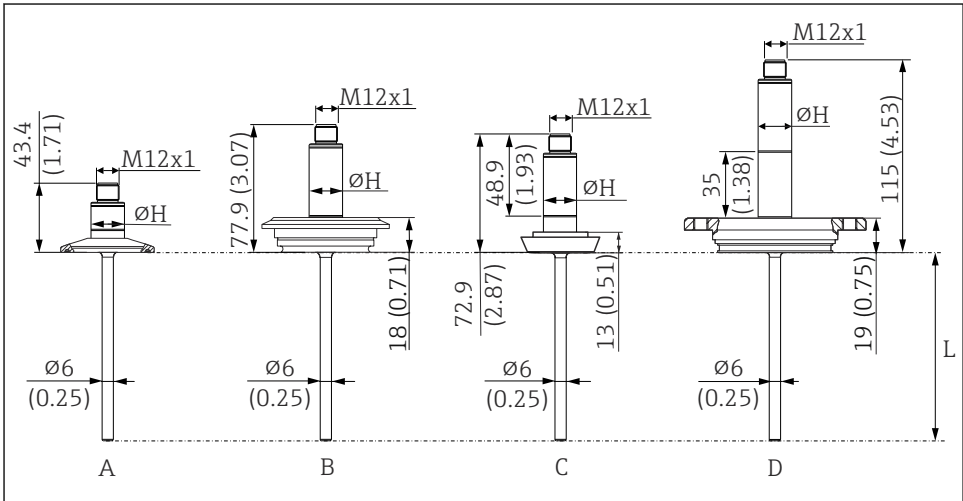

A0018283

8 Dimensions in mm (inch)

L Insertion length L, variable 40 to 600 mm (1.6 to 23.6 in)

ØH Sleeve diameter 18 mm (0.71 in)

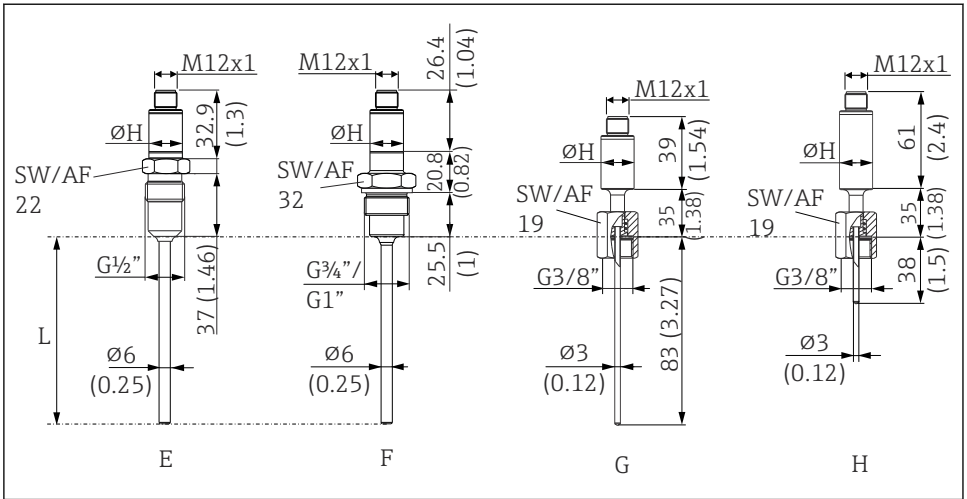

A0044938

9 Dimensions in mm (inch)

L Insertion length L, variable 40 to 600 mm (1.6 to 23.6 in)

ØH Sleeve diameter 18 mm (0.71 in)

Item	Version
A	Shortened sleeve (without built-in transmitter, without extension neck), with 1" clamp process connection (example for minimum length)
B	Without extension neck, process connection Varivent F
C	Without extension neck, process connection according to DIN 11851
D	With extension neck 35 mm (1.38 in), with APV INLINE process connection (example for maximum length)
E	Shortened sleeve (without built-in transmitter, without extension neck), process connection metal sealing system for hygienic processes, G½" thread. Suitable welding boss available as an accessory.
F	Shortened sleeve (without built-in transmitter, without extension neck), process connection for hygienic processes, G¾" or G1" thread, material 316L (1.4404). Suitable Liquiphant weld-in adapter available as an accessory.
G	Shortened sleeve (without built-in transmitter), with extension neck, insertion length 83 mm (3.27 in)
H	With extension neck, insertion length 38 mm (1.5 in)

11.7.3 Weight

0.2 to 2.5 kg (0.44 to 5.5 lbs) for standard versions

11.7.4 Material

The temperatures for continuous operation specified in the following table are only intended as reference values for use of the various materials in air and without any significant

compressive load. The maximum operating temperatures can be reduced considerably in cases where abnormal conditions such as high mechanical load occur or in aggressive media.

Description	Short form	Recommended max. temperature for continuous use in air	Properties
AISI 316L (corresponds to 1.4404 or 1.4435)	X2CrNiMo17-13-2, X2CrNiMo18-14-3	650 °C (1202 °F) ¹⁾	<ul style="list-style-type: none"> ■ Austenitic, stainless steel ■ High corrosion resistance in general ■ Particularly high corrosion resistance in chlorine-based and acidic, non-oxidizing atmospheres through the addition of molybdenum (e.g. phosphoric and sulfuric acids, acetic and tartaric acids with a low concentration) ■ Increased resistance to intergranular corrosion and pitting

- 1) Can be used to a limited extent up to 800 °C (1472 °F) for low compressive loads and in non-corrosive media. More information is available from the sales organization.

11.7.5 Surface roughness

Specifications for product wetted parts in accordance with EN ISO 21920:

Standard surface, mechanically polished ¹⁾	$R_a \leq 0.76 \mu\text{m}$ (30 μin)
Mechanically polished ¹⁾ , buffed ²⁾	$R_a \leq 0.38 \mu\text{m}$ (15 μin) ³⁾
Mechanically polished ¹⁾ , buffed and electropolished	$R_a \leq 0.38 \mu\text{m}$ (15 μin) ³⁾ + electropolished

- 1) Or equivalent treatment that guarantees R_a max.
 2) Not compliant with ASME BPE
 3) T16% for direct-contact measuring inserts without thermowell, not compliant with ASME BPE

11.7.6 Process connections for hygienic applications

All dimensions in mm (in).

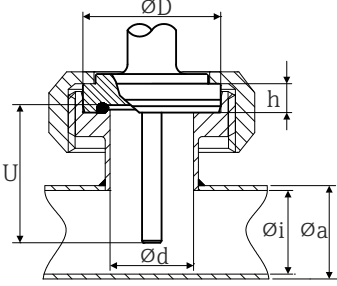
Type	Version	Dimensions					Technical properties
		ϕd	ϕD	ϕi	ϕa	h	
Aseptic pipe union according to DIN 11864-1, Form A 	DN25	26 mm (1.02 in)	42.9 mm (1.7 in)	26 mm (1.02 in)	29 mm (1.14 in)	9 mm (0.35 in)	<ul style="list-style-type: none"> ■ P_{max.} = 40 bar (580 psi) ■ 3-A marked and EHEDG certified ■ ASME BPE compliance
	DN40	38 mm (1.5 in)	54.9 mm (2.16 in)	38 mm (1.5 in)	41 mm (1.61 in)	10 mm (0.39 in)	

Releasable process connection

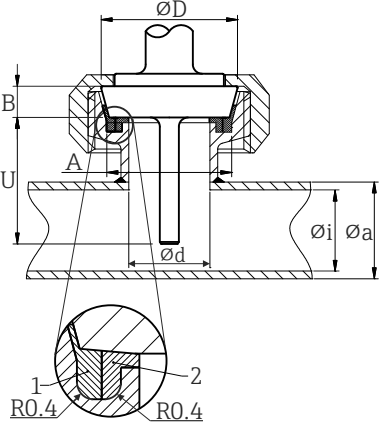
Type	Technical properties																			
Sanitary connection according to DIN 11851  <p>1 Centering ring 2 Sealing ring</p>	<ul style="list-style-type: none"> ■ 3-A marked and EHEDG certified (only with EHEDG-certified and self-centering sealing ring). ■ ASME BPE compliance 																			
<table border="1"> <thead> <tr> <th rowspan="2">Version ¹⁾</th> <th colspan="5">Dimensions</th> <th rowspan="2">P_{max.}</th> </tr> <tr> <th>ϕD</th> <th>A</th> <th>B</th> <th>ϕi</th> <th>ϕa</th> </tr> </thead> <tbody> <tr> <td>DN25</td> <td>44 mm (1.73 in)</td> <td>30 mm (1.18 in)</td> <td>10 mm (0.39 in)</td> <td>26 mm (1.02 in)</td> <td>29 mm (1.14 in)</td> <td>40 bar (580 psi)</td> </tr> </tbody> </table>	Version ¹⁾	Dimensions					P _{max.}	ϕD	A	B	ϕi	ϕa	DN25	44 mm (1.73 in)	30 mm (1.18 in)	10 mm (0.39 in)	26 mm (1.02 in)	29 mm (1.14 in)	40 bar (580 psi)	
Version ¹⁾		Dimensions						P _{max.}												
	ϕD	A	B	ϕi	ϕa															
DN25	44 mm (1.73 in)	30 mm (1.18 in)	10 mm (0.39 in)	26 mm (1.02 in)	29 mm (1.14 in)	40 bar (580 psi)														

Type						Technical properties
DN32	50 mm	36 mm	10 mm	32 mm	35 mm	40 bar (580 psi)
	(1.97 in)	(1.42 in)	(0.39 in)	(1.26 in)	(1.38 in)	
DN40	56 mm	42 mm	10 mm	38 mm	41 mm	40 bar (580 psi)
	(2.2 in)	(1.65 in)	(0.39 in)	(1.5 in)	(1.61 in)	
DN50	68 mm	54 mm	11 mm	50 mm	53 mm	25 bar (363 psi)
	(2.68 in)	(2.13 in)	(0.43 in)	(1.97 in)	(2.1 in)	

1) Pipes in accordance with DIN 11850

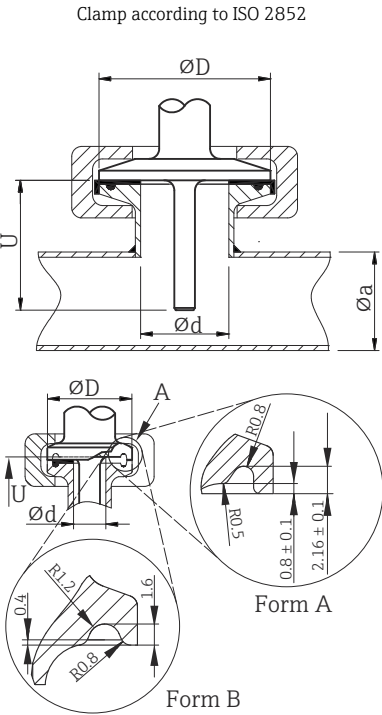
Type	Version ¹⁾	Dimensions		Technical properties	Conformity
	ϕd ²⁾	ϕD	ϕa		
Clamp according to ISO 2852 	Micro clamp ³⁾ DN8-18 (0.5"-0.75") ⁴⁾ , Form A	25 mm (0.98 in)	-	<ul style="list-style-type: none"> ▪ $P_{max.} = 16$ bar (232 psi), depends on clamp ring and suitable seal ▪ With 3-A symbol 	-
	Tri-clamp DN8-18 (0.5"-0.75") ⁴⁾ , Form B		-		-
	Clamp DN12-21.3, Form B	34 mm (1.34 in)	16 to 25.3 m m (0.63 to 0.99 in)		

Form A: In compliance with ASME BPE Type A
 Form B: In compliance with ASME BPE Type B and ISO 2852

A0009566

Type	Version ¹⁾	Dimensions		Technical properties	Conformity
	ϕd ²⁾	ϕD	ϕa		
	Clamp DN25-38 (1"-1.5"), Form B	50.5 mm (1.99 in)	29 to 42.4 mm (1.14 to 1.67 in)	<ul style="list-style-type: none"> ■ $P_{max} = 16$ bar (232 psi), depends on clamp ring and suitable seal ■ 3-A marked and EHEDG certified (in connection with Combifit seal) ■ Can be used with 'Novaseptic Connect (NA Connect)' which enables flush-mount installation 	ASME BPE Type B; ISO 2852
	Clamp DN40-51 (2"), Form B	64 mm (2.52 in)	44.8 to 55.8 mm (1.76 to 2.2 in)		ASME BPE Type B; ISO 2852
	Clamp DN63.5 (2.5"), Form B	77.5 mm (3.05 in)	68.9 to 75.8 mm (2.71 to 2.98 in)		ASME BPE Type B; ISO 2852
	Clamp DN70-76.5 (3"), Form B	91 mm (3.58 in)	> 75.8 mm (2.98 in)		ASME BPE Type B; ISO 2852

- 1) Options depend on product and configuration
- 2) Pipes in accordance with ISO 2037 and BS 4825 Part 1
- 3) Micro clamp (not in ISO 2852); no standard pipes
- 4) DN8 (0.5") only possible with thermowell diameter = 6 mm (¼ in)
- 5) Groove diameter = 20 mm

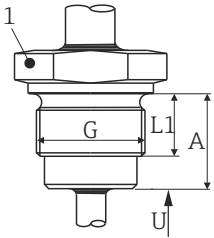
Type	Version G	Dimensions			Technical properties
		L1 thread length	A	1 (SW/AF)	
Thread according to ISO 228 (for Liquiphant weld-in adapter) 	G $\frac{3}{4}$ " for FTL20/31 /33 adapter	16 mm (0.63 in)	25.5 mm (1 in)	32	<ul style="list-style-type: none"> ■ P_{max.} = 25 bar (362 psi) at max. 150 °C (302 °F) ■ P_{max.} = 40 bar (580 psi) at max. 100 °C (212 °F) ■ For more information about hygienic compliance in conjunction with FTL31/33/50 adapters, see Technical Information TI00426F.
	G $\frac{3}{4}$ " for FTL50 adapter				
	G1" for FTL50 adapter	18.6 mm (0.73 in)	29.5 mm (1.16 in)	41	

A0009572

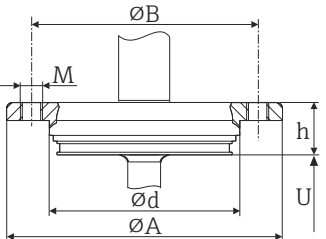
Type	Version	Dimensions					Technical properties
		ϕd	ϕA	ϕB	M	h	
APV Inline 	DN50	69 mm (2.72 in)	99.5 mm (3.92 in)	82 mm (3.23 in)	2xM8	19 mm (0.75 in)	<ul style="list-style-type: none"> ■ P_{max.} = 25 bar (362 psi) ■ 3-A marked and EHEDG certified ■ ASME BPE compliance



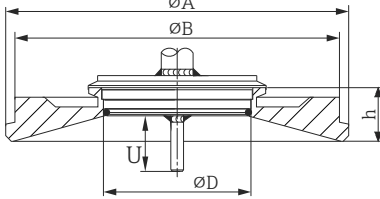

A0018435

Type	Type of fitting ¹⁾	Dimensions				Technical properties	
		∅D	∅A	∅B	h	P _{max.}	
 <p style="text-align: right; font-size: small;">A0021307</p>	Type B	31 mm (1.22 in)	105 mm (4.13 in)	-	22 mm (0.87 in)	10 bar (145 psi)	<ul style="list-style-type: none"> ■ With 3-A symbol and EHEDG certification ■ ASME BPE compliance
	Type F	50 mm (1.97 in)	145 mm (5.71 in)	135 mm (5.31 in)	24 mm (0.95 in)		
	Type N	68 mm (2.67 in)	165 mm (6.5 in)	155 mm (6.1 in)	24.5 mm (0.96 in)		

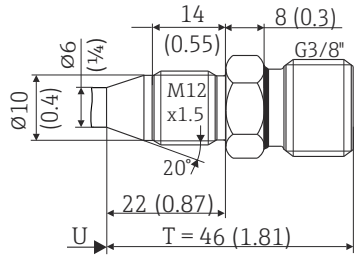
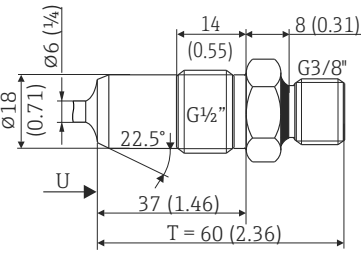

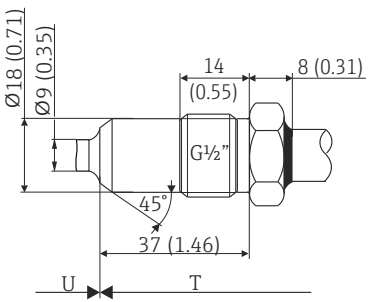
i The VARINLINE® housing connection flange is suitable for welding into the conical or torispherical head in tanks or containers with a small diameter (≤ 1.6 m (5.25 ft)) and up to a wall thickness of 8 mm (0.31 in).
 Varivent® Type F cannot be used for installations in pipes in combination with the VARINLINE® housing connection flange.

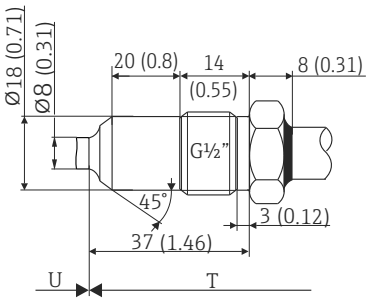
1) Options depend on product and configuration

Type	Version ¹⁾	Technical properties
<p>Metal sealing system</p>  <p style="text-align: right; font-size: x-small;">A0009574</p> <p>10 M12x1.5</p>	<p>Thermowell diameter 6 mm (¼ in)</p>	<p>P_{max.} = 16 bar (232 psi)</p> <p>i Maximum torque = 10 Nm (7.38 lbf ft)</p>
 <p style="text-align: right; font-size: x-small;">A0020856</p> <p>11 G½"</p>		

Type	Version ¹⁾	Technical properties
 <p style="text-align: right;">A0009571</p>	<p>Thermowell diameter 9 mm (0.35 in)</p>	<p>$P_{max.} = 16 \text{ bar (232 psi)}$</p> <p> Maximum torque = 10 Nm (7.38 lbf ft)</p>
 <p style="text-align: right;">A0022326</p>	<p>Thermowell diameter 8 mm (0.31 in)</p>	<p>$P_{max.} = 16 \text{ bar (232 psi)}$</p> <p> Maximum torque = 10 Nm (7.38 lbf ft)</p>

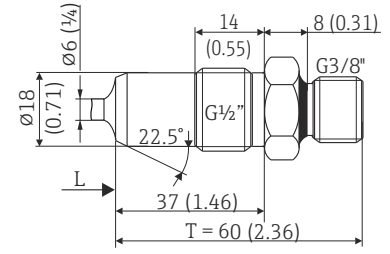
1) Options depend on product and configuration

Type	Version	Technical properties
<p style="text-align: center;">Metal sealing system</p> <p style="text-align: center;">G½"</p>  <p style="text-align: right;">A0045095</p>	<p>Thermowell diameter 6 mm (¼ in)</p>	<p>$P_{max.} = 16 \text{ bar (232 psi)}$</p> <p> Maximum torque = 10 Nm (7.38 lbf ft)</p>

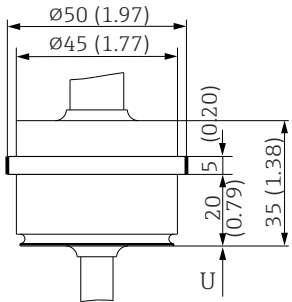
Type	Version	Technical properties
<p style="text-align: center;">Process adapter</p>  <p style="text-align: right;">A0034881</p> <p style="text-align: center;"><i>Unit of measurement mm (in)</i></p>	<p>D45</p>	

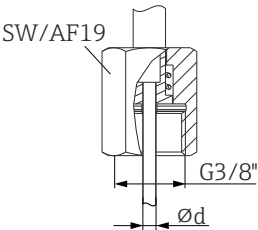
Type	Version	Technical properties
<p style="text-align: center;">Spring-loaded cap-nut</p>  <p style="text-align: right;">A0044937</p>	<p>Thread G3/8" as connection piece for installation in a thermowell (available or can be ordered separately, e.g. iTHERM ModuLine TT411).</p>	<p>-</p>

11.7.7 Thermowell design, dimensions

Thermometers for hygienic applications

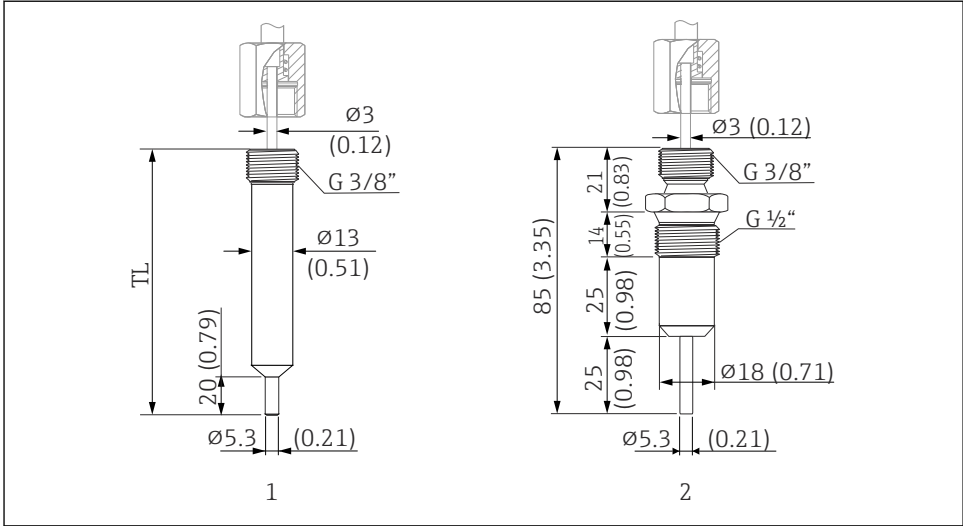

A0018305

12 Thermowell for connection to the compact thermometer with spring-loaded cap-nut and G3/8" thread. Dimensions in mm (inch)

- 1 Cylindrical thermowell, TL = 70 mm (2.76 in), option WA or 85 mm (3.35 in), option WB, with 3-A® symbol, $P_{max.} = 250 \text{ bar}$ (3 626 psi) with maximum flow velocity of 40 m/s (131 ft/s)
- 2 Thermowell, metal-to-metal seal, $P_{max.} = 16 \text{ bar}$ (232 psi)

11.8 Certificates and approvals

Current certificates and approvals for the product are available at www.endress.com on the relevant product page:

1. Select the product using the filters and search field.
2. Open the product page.
3. Select **Downloads**.

11.8.1 Hygiene standard

- EHEDG certification, type EL CLASS I. EHEDG-certified/tested process connections. → 34
- 3-A Authorization No. 1144, 3-A Sanitary Standard 74-07. Listed process connections.
→ 34
- ASME BPE, declaration of conformity can be ordered for options indicated
- FDA-compliant
- All surfaces in contact with the medium are free from materials derived from bovine animals or other livestock (ADI/TSE)

11.8.2 Materials in contact with food/product (FCM)

The process contact parts (FCM) are in conformity with the following European Regulations:

- Regulation (EC) No 1935/2004, on materials and articles intended to come into contact with food, article 3, paragraph 1, article 5 and 17.
- Regulation (EC) No 2023/2006 on good manufacturing practice for materials and articles intended to come into contact with food.
- Regulation (EU) No 10/2011 on plastic materials and articles intended to come into contact with food.



71716261

www.addresses.endress.com
